

BHS-Series

φ 2.34柄-鑽石雕刻針 Diamond Engraving Burrs

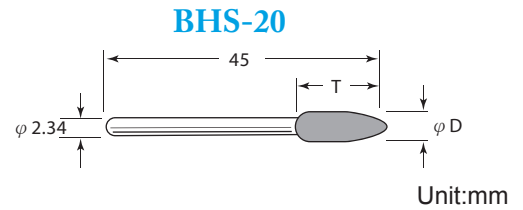

Shank: φ 2.34mm / Length:45~50mm

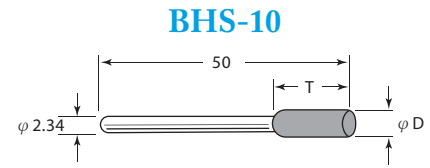

型號 Model No.	BH160E	BH60Q	BH60R	BH30A	BH25K	BH25J	BH25F	BH30V	BH15P	BH20B
刃徑 φ D	16	6.0	6.0	3.0	2.5	2.5	2.5	2.5	1.5	2.0
刃長 T	0.5	10	14	15	10	10	6	45°	10	-
長度 L	50	50	50	50	50	50	45	45	45	45
單價 Price										

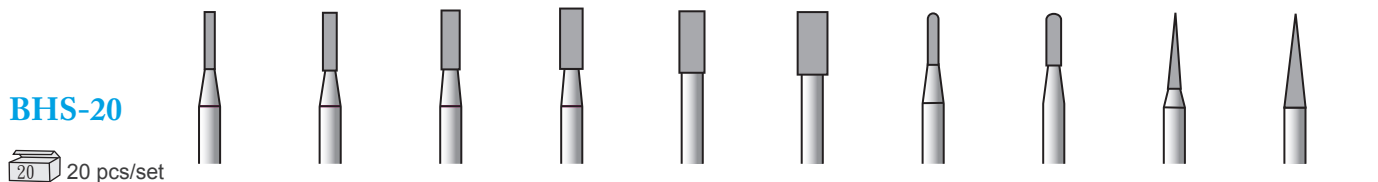

型號 Model No.	BH11A	BH14A	BH19A	BH24A	BH27A	BH32A	BH14C	BH19C	BH18P	BH24P
刃徑 φ D	1.1	1.4	1.9	2.4	2.7	3.2	1.4	1.9	1.8	2.4
刃長 T	7	7	7	7	7	7	7	7	10	12
長度 L	45	45	45	45	45	45	45	45	45	45
單價 Price										

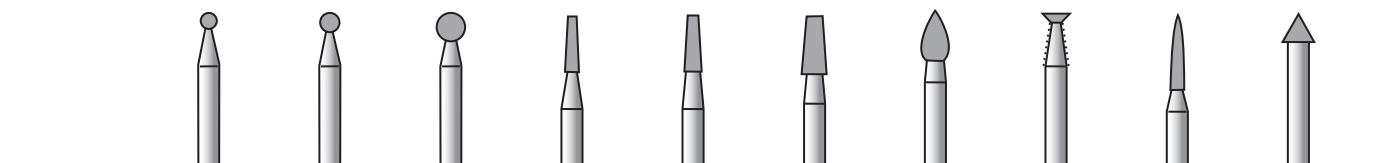

型號 Model No.	BH20B	BH24B	BH35B	BH14T	BH19T	BH26T	BH34S	BH30Y	BH17J	BH42P
刃徑 φ D	2.0	2.4	3.5	1.4	1.9	2.6	3.4	3.0	1.7	4.2
刃長 T	-	-	-	7	7	7	6	-	10	6
長度 L	45	45	45	45	45	45	45	45	45	45
單價 Price										

BHS-030

φ 2.34柄-鑽石雕刻針 Diamond Engraving Burrs



Shank: φ 2.34mm / Length:45mm



適用於金屬、玻璃等物品研磨修整用。

Shorter shank diamond burrs designed for use in the friction grip highspeed handpiece when easier access is required.

Used for contouring, carving, and finishing thin margins of porcelain and metal frame work.

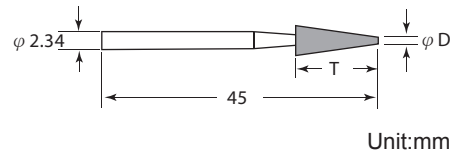

30 pcs/set

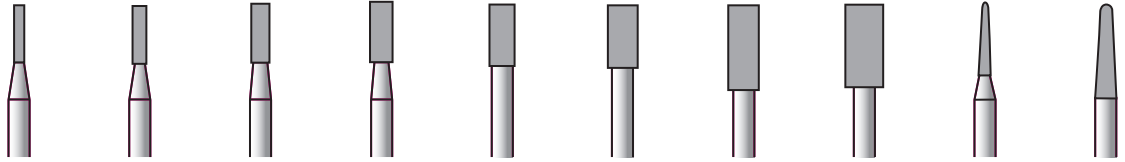

型號 Model No.	BH11A	BH14A	BH19A	BH24A	B27A	BH32A	BH39A	BH49A	BH14R	BH24R
刃徑 φD	1.1	1.4	1.9	2.4	2.7	3.2	3.9	4.9	1.4	2.4
刃長 T	7	7	7	7	7	7	10	10	10	13
長度 L	45	45	45	45	45	45	45	45	45	45
單價 Price										

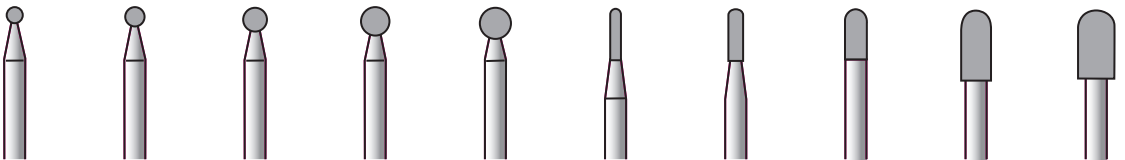

型號 Model No.	BH20B	BH24B	BH30B	BH35B	BH39B	BH14C	BH19C	BH29C	BH39C	BH49C
刃徑 φD	2.0	2.4	3.0	3.5	3.9	1.4	1.9	2.9	3.9	4.9
刃長 T	-	-	-	-	-	7	7	7	10	10
長度 L	45	45	45	45	45	45	45	45	45	45
單價 Price										

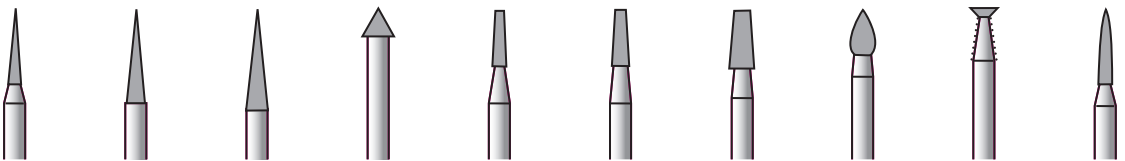

型號 Model No.	BH18P	BH24P	BH29P	BH42P	BH14T	BH19T	BH26T	BH30S	BH30Y	BH17J
刃徑 φD	1.8	2.4	2.9	4.2	1.4	1.9	2.6	3.0	3.0	1.7
刃長 T	10	12	14	6	7	7	7	6	-	10
長度 L	45	45	45	45	45	45	45	45	45	45
單價 Price										

BH-Series

φ2.34柄-鑽石雕刻針 Diamond Engraving Burrs



Shank: φ 2.34mm / Length: 45mm

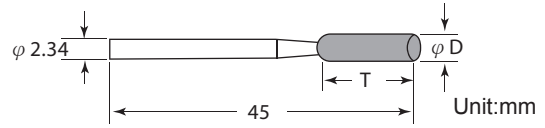

30 pcs/set

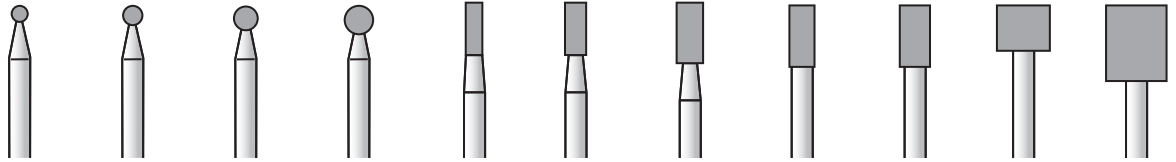

型號 Model No.	D1	D2	D3	D4	A11	A12	A13	A21	A30	7A	8A
刃徑 φD	1	2	3	4	1	1.5	1.5	2.5	3	7	8
刃長 T	-	-	-	-	5	5	7	7	7	6	10
長度 L	45	45	45	45	45	45	45	45	45	45	45
單價 Price											

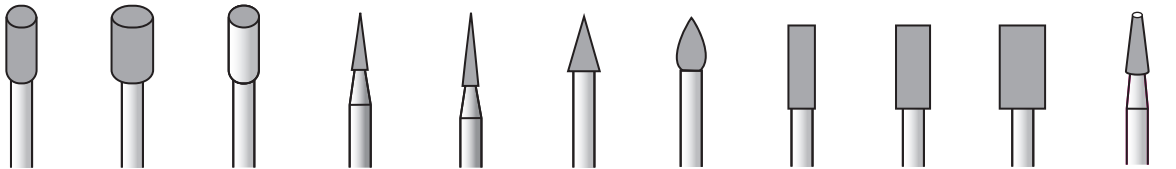

型號 Model No.	A20	A31	A14	TR	1R	KS	RZ	3A	5A	6A	2LB
刃徑 φD	2.5	3	2.5	1.5	1.5	3.5	4	3	4	5	2.5
刃長 T	7	7	7	8	10	6	6	10	10	10	10
長度 L	45	45	45	45	45	45	45	45	45	45	45
單價 Price											

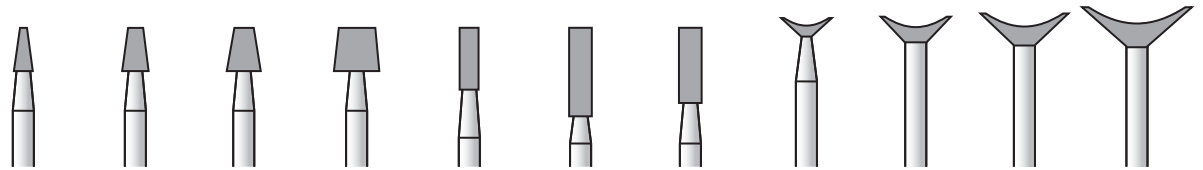

型號 Model No.	T11	T12	T13	T30	1A	2A	2LA	12BA	14BA	16BA	19BA
刃徑 φD	1	1.5	2	3	2	2.5	2.5	4	6	10	12
刃長 T	4	4	4	4	8	12	10	-	-	-	-
長度 L	45	45	45	45	45	45	45	45	45	45	45
單價 Price											

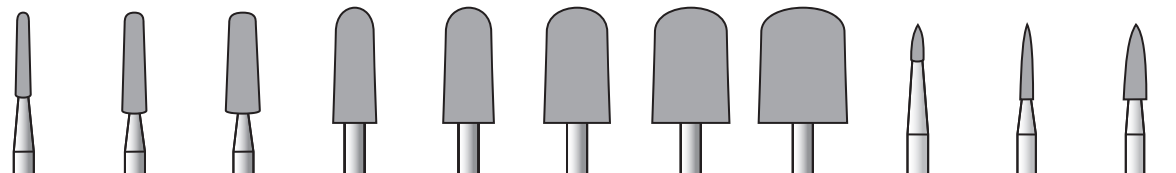

型號 Model No.	1LR	2R	2LR	3R	5R	6R	7R	8R	C3	C13	C23
刃徑 φD	1.5	2	2.5	3	4	5	7	8	0.9	1.5	2
刃長 T	10	12	12	12	12	12	12	12	4	10	10
長度 L	45	45	45	45	45	45	45	45	45	45	45
單價 Price											

Shank: φ 2.34mm / Length: 45mm

鑽石雕刻針 - 柄徑φ2.34mm 適用於木質、纖維、塑膠、金屬等精細雕刻用

These small engraving cutters are ideal for power engraving intricate details in wood, fiber, plastic and soft materials. All φ2.34mm shanks.

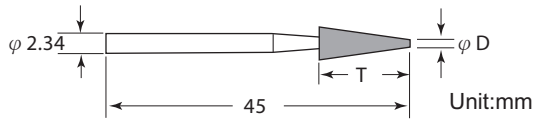

30 pcs/set

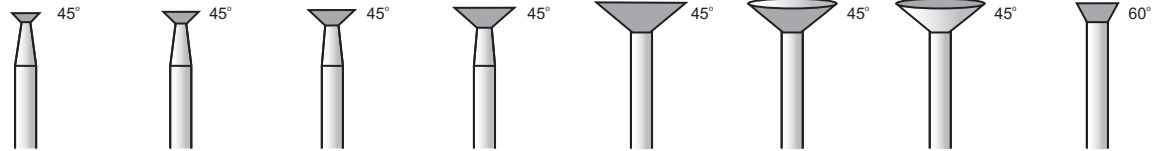

型號 Model No.	10B	12B	13B	14B	16B	16BB	16BC	13NK
刃徑 φD	2.7	4	5	6	10	10	10	5
刃長 T	-	-	-	-	5	5	7	7
長度 L	45	45	45	45	45	45	45	45
單價 Price								

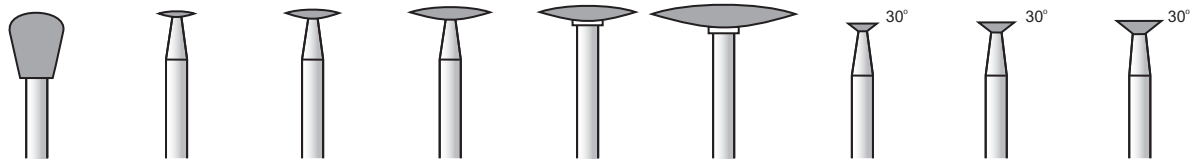

型號 Model No.	RT	10X	17X	18X	19X	23X	10BN	12BN	13BN
刃徑 φD	5	1.8	4	6	10	16	2.5	4	5
刃長 T	7	0.5	0.8	1	1.6	2	-	-	-
長度 L	45	45	45	45	45	45	45	45	45
單價 Price									

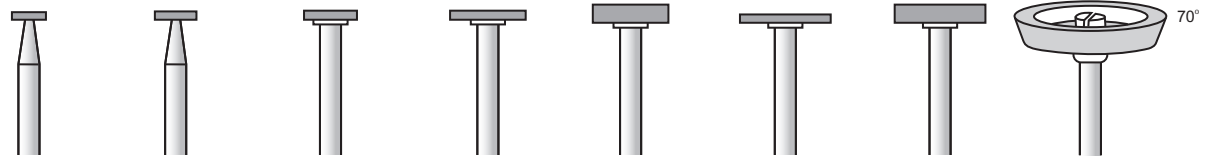

型號 Model No.	K25	K30	K35	K45	K50	K55	K60	20MA
刃徑 φD	4	5	6	10	10	12	12	20
刃長 T	0.4	0.6	0.5	0.5	1	0.6	1	3.5
長度 L	45	45	45	45	45	45	45	45
單價 Price								

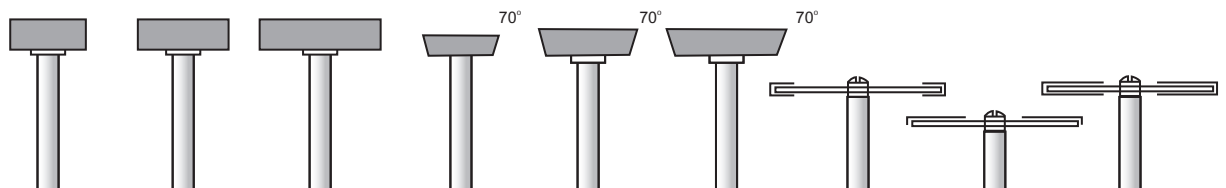

型號 Model No.	13MB	16MC	16MB	10MA	13MA	16MA	88D	88C	88A
刃徑 φD	13	16	16	10	13	16	22	22	22
刃長 T	2.5	2.5	3.5	2.5	3.5	3.5	0.45	0.35	0.45
長度 L	45	45	45	45	45	45	45	45	45
單價 Price									

B
鑽石銼刀
鑽石磨棒
鑽石砂輪
鑽石修刀
鑽石膏
超級油石
錫鋼刀
毛刷
羊毛輪
拋磨工具
電動工具
氣動工具

BM-Series

φ3柄-鑽石與氮化硼磨棒 Diamond & CBN Mounted Points



Shank: φ 3.0mm / Length:45mm



型號 Model No.	10A	15A	20A	25A	30A	35A	40A	50A	60A	80A	20T	30T
刃徑 φD	1.0	1.5	2.0	2.5	3.0	3.5	4.0	5.0	6.0	8.0	2.0	3.0
刃長 T	8	8	8	8	10	10	10	10	10	10	10	10
單價 Price												



型號 Model No.	10B	15B	20B	25B	30B	40B	50B	60B	80B	15R	20R	30R
刃徑 φD	1.0	1.5	2.0	2.5	3.0	4.0	5.0	6.0	8.0	1.5	2.0	3.0
刃長 T	1	1.5	2	2.5	3	4	5	6	8	12	12	14
單價 Price												

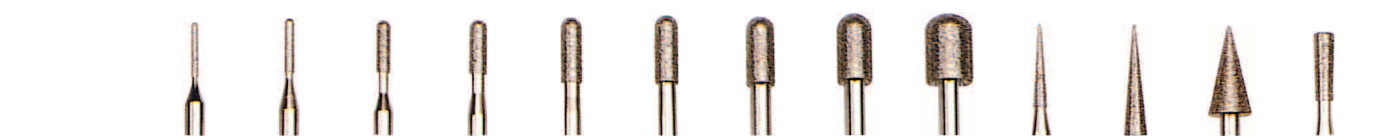

型號 Model No.	10C	15C	20C	25C	30C	35C	40C	50C	60C	20P	30P	60P	30V
刃徑 φD	1.0	1.5	2.0	2.5	3.0	3.5	4.0	5.0	6.0	7°	10°	26°	3.0
刃長 T	8	8	8	8	10	10	10	10	10	12	15	13	10
單價 Price													



型號 Model No.	20F	30F	40F	50F	60F	30J	40J	50J	60J	50G	60G	30Q	60Q
刃徑 φD	2.0	3.0	4.0	5.0	6.0	3.0	4.0	5.0	6.0	5.0	6.0	3.0	6.0
刃長 T	10	10	10	10	10	15	13	13	13	12	12	5	10
單價 Price													

Shank: φ 3.0mm / Length: 45mm

新品

光滑的切口表面，適用高速鑽頭。
適用在碳化物、陶瓷、青玉、玻璃、堅硬合金等
精密小孔研磨

Smooth cutting surface, high drilling speed.
Used for precision grinding of small holes in
carbide, ceramics, sapphires, glass and extra
hard alloys.

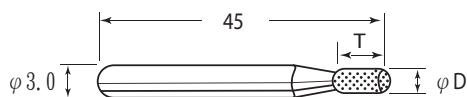

30 pcs/set



型號 Model No.	6010U	6020U	6030U	6040U	6010E	6015E	6020E	30X	30Y	30Z	30S	60S
刃徑 φD	6.0	6.0	6.0	6.0	6.0	6.0	6.0	3.0	3.0	3.3	3.0	6.0
刃長 T	1	2	3	4	1	1.5	2	6	5	6	6	10
單價 Price												



型號 Model No.	60M	80M	130M	60W	80W	130W	1310H	1315H
刃徑 φD	6.0	8.0	13	6.0	8.0	13	13	13
刃長 T	3.5	3.5	3.5	3.5	3.5	3.5	1.0	1.5
單價 Price								



型號 Model No.	1310U	1315U	1320U	1325U	1330U	1335U	1340U	1345U
刃徑 φD	13	13	13	13	13	13	13	13
刃長 T	1	1.5	2.0	2.5	3	3.5	4	4.5
單價 Price								



型號 Model No.	1310E	1315E	1320E	1325E	1330E	1335E	1340E	1345E
刃徑 φD	13	13	13	13	13	13	13	13
刃長 T	1	1.5	2.0	2.5	3	3.5	4	4.5
單價 Price								

BC-Series

φ6柄-鑽石磨棒 Diamond Mounted Points



Shank: φ 6.0mm / Length:60mm Grit Size:#40, #60, #100 available.

新品



BC-10 Standard Package:10pcs/set



Contains one each of marking * :

BC80B, 80V, 100E, 65C, 80A, 80P, 80T, 65F, 80F, 65R

Unit:mm

型號 Model No.	BC-65A	BC-80A*	BC-100A	BC-101A	BC-102A	BC-180A	BC-200A
刃徑 φD	6.5	8	10	10	10	18	20
刃長 T	15	15	19	10	32	26	12
單價 Price							



型號 Model No.	BC-80B*	BC-100B	BC-160B	BC-200B	BC-65F*	BC-80F*	BC-100F
刃徑 φD	8	10	16	20	6.5	8	10
刃長 T	8	10	16	20	22	15	19
單價 Price							



型號 Model No.	BC-60C	BC-65C*	BC-80C	BC-100C	BC-65J	BC-70J	BC-100J
刃徑 φD	6	6.5	8	10	6.5	7	10
刃長 T	32	15	15	19	21	35	19
單價 Price							



型號 Model No.	BC-100E*	BC-120E	BC-200E	BC-250E	BC-100K	BC-140K	BC-160K
刃徑 φD	10	12	20	25	10	14	16
刃長 T	1.2	2	1.5	2	38	18	18
單價 Price							



BC-Series

φ6柄-鑽石磨棒 Diamond Mounted Points



Shank: φ 6.0mm / Length: 60mm Grit Size: #40, #60, #100 available.

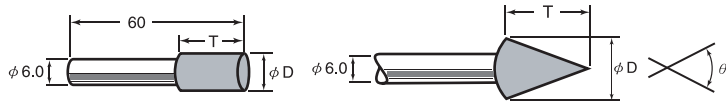

鑽石帶柄磨棒能廣泛運用在電/氣動手工具上
Mounted points wheels can be used on a wide range of pneumatics, electric and flexible drive tools.



型號 Model No.	BC-50P	BC-60P	BC-80P*	BC-100P	BC-55H	BC-80T*	BC-100N
刃徑 φD	5	6	8	10	5.5	8	10
刃長 T	20	15	15	20	17	15	9
單價 Price							



型號 Model No.	BC-80V*	BC-81V	BC-120V	BC-140V	BC-160V	BC-200V	BC-250V
刃徑 φD	8	8	12	14	16	20	25
刃長 T	5	10	15	18	5	6	7
單價 Price							



型號 Model No.	BC-150Y	BC-170Y	BC-200Y	BC-250Y	BC-130-H	BC-170H	BC-100G	BC-65R*
刃徑 φD	15	17	20	25	13	17	10	6.5
刃長 T	9	10	8	8	10	11	26	25
單價 Price								



型號 Model No.	BC-60Q	BC-90Q	BC-100Q	BC-120Q	BC-150Q	BC-200X	BC-120U	BC-250U
刃徑 φD	6	9	10	12	15	20	12	25
刃長 T	13	18	16	25	29	4	2	5
單價 Price								

Customer's Package upon request.